3. SWITCHED ACCESS SERVICE

3.1. GENERAL

Switched Access Service, which is available to customers for their use in furnishing their services to end users, provides a two-point communications path between a customer's premises and an end user's premises. It provides for the use of common terminating, switching and trunking facilities. Switched Access Service provides for the ability to originate calls from an end user's premises to a customer's premises, and to terminate calls from a customer's premises to an end user's premises in the LATA where it is provided. Switched Access Service must be ordered separately for each LATA in which the customer desires to originate or terminate calls.

3.2. PROVISION AND DESCRIPTION

Switched Access Service is provided in two service categories of standard and optional features called Feature Groups. The Company provides Feature Group B and Feature Group D originating and terminating Switched Access. The service categories are differentiated by their technical characteristics and the manner in which an end user accesses them when originating calls.

3.2.1. FEATURE GROUP B

FGB Access, which is available to all customers, provides trunk side access to Company End Office switches with an associated uniform 950-XXXX access code for the customer's use in originating and terminating communications.

3.2.2. FEATURE GROUP D

FGD Access, which is available to all customers, provides trunk side access to Company End Office switches with an associated uniform 10XX-XXX access code for the customer's use in originating and terminating communications. No access code is required for calls to a customer over FGD if the end user's telephone exchange service is arranged for presubscription to that customer.

3.2.3. 8XX TOLL-FREE ACCESS SERVICE

8XX Toll-Free Access Service is a service offering utilizing originating trunk side Switched Access Service. The service provides for the forwarding of end user dialed 8XX calls to a Company Service Switching Point, which will initiate a query to the database to perform the customer identification and delivery function. The call is forwarded to the appropriate customer based on the dialed 8XX number.

Issued: February 15, 2006

By:

David Lloyd, Director - Tariffs
183 Inverness Drive West
Englewood, CO 80112

Effective: May 22, 2006

3. SWITCHED ACCESS SERVICE

3.3. SWITCHED ACCESS RATE CATEGORIES

The rate categories that apply to Switched Access Service are as follows:

- Carrier Common Line
- Transport (includes Common Transport, Direct-Trunked Transport and Local Channel/Entrance Facilities)
- Local Switching
- 8XX Toll-Free Access Service

The following diagram depicts a generic view of the components of Switched Access Service and the manner in which the components are combined to provide a complete access service.

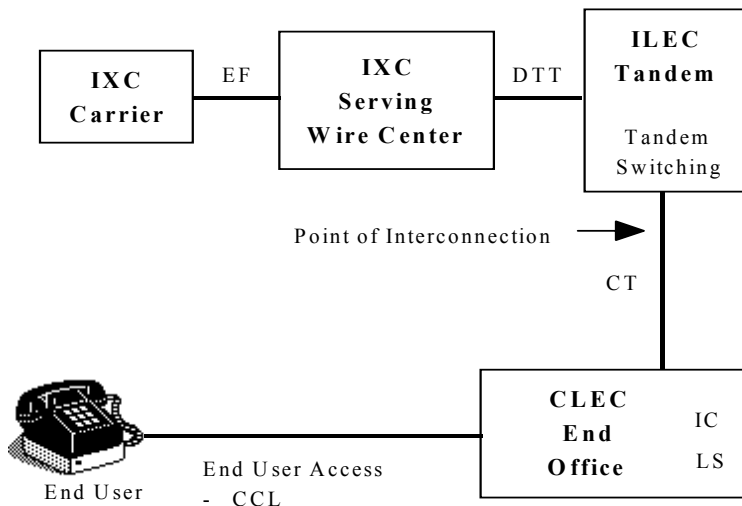

ILEC bills:

EF - Entrance Facility
DTT - Direct Trunk Transport
Tandem Switching

Company bills:

CT - Common Transport
IC - Interconnection Charge
LS - End Office/Local Switching
CCL - Carrier Common Line

Switched Access rates are as set forth in Section 3.4, following.

3. SWITCHED ACCESS SERVICE

3.3. SWITCHED ACCESS RATE CATEGORIES (CONT'D)

3.3.1. CARRIER COMMON LINE

The Carrier Common Line rate category provides for the use of Company common lines by customers for access to end users to furnish customer intrastate communications.

A. Limitations

1. A telephone number is not provided with Carrier Common Line.
2. Detail billing is not provided for Carrier Common Line.
3. Directory listings are not included in the rates and charges for Carrier Common Line.
4. Intercept arrangements are not included in the rates and charges for Carrier Common Line.
5. All trunk side connections provided in the same combined access group will be limited to the same features and operating characteristics.

B. Rate Regulations

Where the customer is provided with Switched Access Service under this Tariff, the Company will provide the use of Company common lines by a customer for access to end users.

1. The Carrier Common Line charges will be billed per access minute to each Switched Access Service customer.
2. When the customer reports interstate and intrastate use of Switched Access Service, the Carrier Common Line charges will be billed only to intrastate.
3. All Switched Access Service provided to the customer will be subject to Carrier Common Line charges.

Issued: February 15, 2006

By:

David Lloyd, Director - Tariffs
183 Inverness Drive West
Englewood, CO 80112

Effective: May 22, 2006

3. SWITCHED ACCESS SERVICE

3.3. SWITCHED ACCESS RATE CATEGORIES (CONT'D)

3.3.2. TRANSPORT

The Transport rate category provides for transmission facilities between the customer's premises and the End Office or Access Tandem switch(es) where the customer's traffic is switched to originate or terminate its communications.

Switched Transport is a two-way voice-frequency transmission path which may consist of an Entrance Facility (EF), Direct-Trunked Transport (DTT) Facility, or Common Transport.

A. Common Transport

The Common Transport rate category provides for transmission facilities between the Company's End Office and an alternate tandem provider's network.

1. Transport Termination

The Transport Termination element includes the non-distance sensitive portion of Switched Transport and is assessed on a per-access-minute-of-use basis.

2. Transport Mileage

The Transport Mileage element includes the distance sensitive portion of Switched Transport and is assessed on a per-access-minute-of-use-per-mile basis.

3. SWITCHED ACCESS SERVICE

3.3. SWITCHED ACCESS RATE CATEGORIES (CONT'D)

3.3.2. TRANSPORT (CONT'D)

B. Direct-Trunked Transport

1. Voice Grade/DSO Facility

A Voice Grade facility is an electrical communications path which provides voice-frequency transmission in the nominal frequency range of 300 to 3000 HZ and may be terminated two-wire or four-wire.

2. DS1 Facility

A DS1 facility is capable of transmitting electrical signals at a nominal 1.544 Mbps, with the capability to channelize up to 24 voice-frequency transmission paths.

3. DS3 Facility

A DS3 facility is capable of transmitting electrical signals at a nominal 44.736 Mbps, with the capability to channelize up to 672 voice-frequency transmission paths.

C. Local Channel/Entrance Facility

The Local Channel/Entrance Facility provides a communications path between the customer's premises and the serving wire center of that premises. The Local Channel/Entrance Facility rate is assessed a monthly fixed charge based on the capacity (e.g., Voice Grade/DS0, DS1, or DS3) ordered.

3. SWITCHED ACCESS SERVICE

3.3. SWITCHED ACCESS RATE CATEGORIES (CONT'D)

3.3.3. LOCAL SWITCHING

The Local Switching rate category provides the local end office switching and end user termination functions necessary to complete the transmission of Switched Access communications to and from the end users served by the Company's End Office.

A. Local Switching Rate Element

The Local Switching rate element provides local dial switching for Feature Groups B and D.

B. Common Trunk Port

The end office Common Trunk Port rate provides for the termination of common transport trunks in shared end office ports. The end office Common Trunk Port rate is assessed on a per-MOU basis to all trunkside originating and terminating access minutes utilizing tandem routing to an end office.

C. Dedicated Trunk Port

The end office Dedicated Trunk Port rate provides for the termination of a trunk to a dedicated trunk port in an end office. The rate is assessed per month for each FG trunk in service directly routed (via DTT) between the SWC and the end office.

D. Interconnection Charge

The Interconnection Charge shall be assessed upon all customers interconnecting with the Company's switched access network. Interconnection is applicable to all switched access originating and terminating minutes of use.

3. SWITCHED ACCESS SERVICE

3.3. SWITCHED ACCESS RATE CATEGORIES

3.3.4. 8XX TOLL-FREE ACCESS SERVICE

8XX Toll-Free Access Service is a service offering originating trunk side Switched Access Service. The service provides for the forwarding of end user dialed 8XX calls to a Company Service Switching Point, which will initiate a query to the database to perform the customer identification and delivery functions. The call is forwarded to the appropriate customer based on the dialed 8XX number. In addition, the customer has the option of selecting the 8XX Optional Features Package.

A. Customer Identification Charge

The 8XX Toll-Free Access Service Customer Identification Charge applies for the identification and delivery of the appropriate customer. The charge is assessed to the customer on a per query basis and may include an area of service which may range from a single NPA-NXX to an area consisting of all LATAs and NPAs within the state. The 8XX Customer Identification Charge is set forth in Section 3.4.5.

B. POTS Translation Charge

The POTS Translation Charges provides the option of having the ten digit POTS number NPA + NXX-XXXX delivered instead of the 8XX dialed number 8XX + NXX-XXXX delivered to the service provider.

A POTS Translation Charge is assessed per call in addition to the 8XX Customer Identification Charge.

C. Call Handling and Destination Feature Charge

The 8XX Optional Features Package, available only with 8XX Toll-Free Access Service, provides feature functionality in addition to the basic query. The feature package may include various destination options such as carrier selection, time of day routing, day of week routing, specific date routing, geographic routing, routing based on percent of allocation, and emergency routing profiles.

A Call Handling and Destination Feature Charge is assessed on a per-query basis, in addition to the Customer Identification Charge and the POTS Translation Charge.

3. SWITCHED ACCESS SERVICE

3.4. SWITCHED ACCESS RATES AND CHARGES (CONT'D)

3.4.1. SERVICE IMPLEMENTATION

	NONRECURRING CHARGE
A. Installation Charge, Per Location, Per Order	
1. First Trunk	\$0.00
2. Each Subsequent Trunk	0.00

3.4.2. CARRIER COMMON LINE

	RECURRING RATE PER MOU
A. Originating	\$0.000000
B. Terminating	0.000000

3.4.3. TRANSPORT

A. Common Transport	
1. Transport Termination	\$.000176
2. Transport Mileage, per mile	0.000023

Issued: February 15, 2006

By:

David Lloyd, Director - Tariffs
183 Inverness Drive West
Englewood, CO 80112

Effective: May 22, 2006

3. SWITCHED ACCESS SERVICE

3.4. SWITCHED ACCESS RATES AND CHARGES (CONT'D)

3.4.3. TRANSPORT (CONT'D)

B. Local Channel/Entrance Facility

	NONRECURRING CHARGE		MONTHLY RATE
	FIRST	ADD'L	
1. VG/DS0	\$0.00	\$0.00	ICB
2. DS1	0.00	0.00	ICB
3. DS3	0.00	0.00	ICB

C. Direct Trunked Transport

	NONRECURRING CHARGE		MONTHLY RATE
	FIRST	ADD'L	
1. VG			
• Per Mile	-		ICB
• Termination	\$0.00		ICB
2. DS0			
• Per Mile	-		ICB
• Termination	0.00		ICB
3. DS1			
• Per Mile	-		ICB
• Termination	0.00		ICB
4. DS3			
• Per Mile	-		ICB
• Termination	0.00		ICB

Issued: February 15, 2006

By:

David Lloyd, Director - Tariffs
183 Inverness Drive West
Englewood, CO 80112

Effective: May 22, 2006

3. SWITCHED ACCESS SERVICE

3.4. SWITCHED ACCESS RATES AND CHARGES (CONT'D)

3.4.4. LOCAL SWITCHING

A. Local Switching	RECURRING RATE PER MOU
1. Originating Access	\$0 002748
2. Terminating Access	0 002748
3. Common Trunk Port	0.000800
4. Interconnection Charge	0.000000
	MONTHLY RATE
5. Dedicated Trunk Port	
a. DS0/VG, per trunk	ICB
b. DS1, per trunk	ICB

3.4.5. 8XX TOLL-FREE ACCESS SERVICE

A. 8XX Toll-Free Access Service	RECURRING RATE PER QUERY
1. Customer Identification Charge	\$0 004210
2. POTS Translation Charge	0.000000
3. Call Handling and Destination Feature Charge	0.000000

Issued: February 15, 2006

By:

David Lloyd, Director - Tariffs
183 Inverness Drive West
Englewood, CO 80112

Effective: May 22, 2006