

**ACCESS SERVICE TARIFF**Issued: August 19, 2003Effective: September 19, 2003**3. SWITCHED ACCESS SERVICE****3.1. GENERAL**

Switched Access Service, which is available to Customers for their use in furnishing their services to end users, provides a two-point communications path between a Customer's premises and an end user's premises. It provides for the use of common terminating, switching and trunking facilities. Switched Access Service provides for the ability to originate calls from an end user's premises to a Customer's premises, and to terminate calls from a Customer's premises to an end user's premises in the LATA where it is provided. Switched Access Service must be ordered separately for each LATA in which the Customer desires to originate or terminate calls.

**3.2. PROVISION AND DESCRIPTION**

Switched Access Service is provided in two service categories of standard and optional features called Feature Groups. The Company provides Feature Group B and Feature Group D originating and terminating Switched Access. The service categories are differentiated by their technical characteristics and the manner in which an end user accesses them when originating calls.

**3.2.1. FEATURE GROUP B**

FGB Access, which is available to all Customers, provides trunk side access to Company End Office switches with an associated uniform 950-XXXX access code for the Customer's use in originating and terminating communications.

**3.2.2. FEATURE GROUP D**

FGD Access, which is available to all Customers, provides trunk side access to Company End Office switches with an associated uniform 10XX-XXX access code for the Customer's use in originating and terminating communications. No access code is required for calls to a Customer over FGD if the end user's telephone exchange service is arranged for presubscription to that Customer.

**3.2.3. 8XX TOLL-FREE ACCESS SERVICE**

8XX Toll-Free Access Service is a service offering utilizing originating trunk side Switched Access Service. The service provides for the forwarding of end user dialed 8XX calls to a Company Service Switching Point which will initiate a query to the database to perform the Customer identification and delivery function. The call is forwarded to the appropriate Customer based on the dialed 8XX number.

Comcast Phone of Colorado, LLC

David M. Lloyd, Director

183 Inverness Drive West, Suite 200

Englewood, CO 80112

**ACCESS SERVICE TARIFF**

Issued: August 19, 2003

Effective: September 19, 2003

**3. SWITCHED ACCESS SERVICE**

**3.3. SWITCHED ACCESS RATE CATEGORIES**

The rate categories that apply to Switched Access Service are as follows:

- Carrier Common Line
- Transport (includes Common Transport, Direct Trunk Transport and Local Channel/Entrance Facilities)
- Local Switching
- 8XX Toll-Free Access Service

The following diagram depicts a generic view of the components of Switched Access Service and the manner in which the components are combined to provide a complete access service.

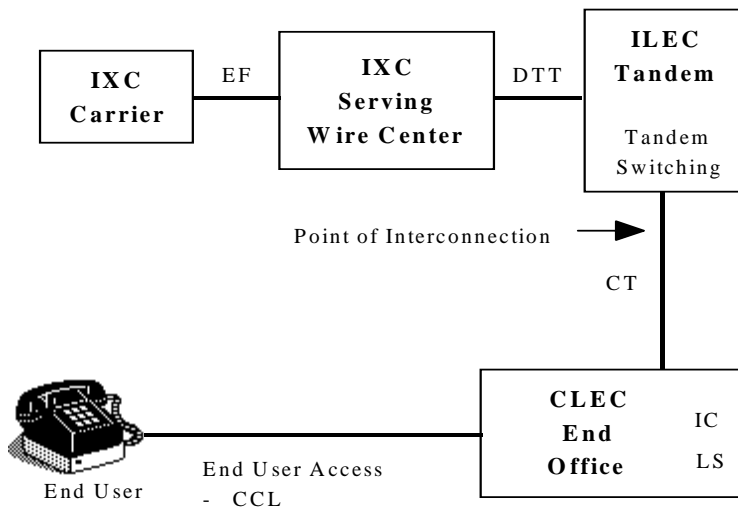

ILEC bills:

EF - Entrance Facility  
 DTT - Direct Trunk Transport  
 Tandem Switching

Company bills:

CT - Common Transport  
 IC - Interconnection Charge  
 LS - End Office/Local Switching  
 CCL - Carrier Common Line

Switched Access rates are as set forth in Section 3.4, following.

**ACCESS SERVICE TARIFF**

Issued: August 19, 2003

Effective: September 19, 2003

**3. SWITCHED ACCESS SERVICE**

**3.3. SWITCHED ACCESS RATE CATEGORIES (CONT'D)**

**3.3.1. CARRIER COMMON LINE**

The Carrier Common Line rate category provides for the use of Company common lines by Customers for access to end users to furnish Customer intrastate communications.

A. Limitations

1. A telephone number is not provided with Carrier Common Line.
2. Detail billing is not provided for Carrier Common Line.
3. Directory listings are not included in the rates and charges for Carrier Common Line.
4. Intercept arrangements are not included in the rates and charges for Carrier Common Line.
5. All trunk side connections provided in the same combined access group will be limited to the same features and operating characteristics.

B. Rate Regulations

Where the Customer is provided with Switched Access Service under this Tariff, the Company will provide the use of Company common lines by a Customer for access to end users.

1. The Carrier Common Line charges will be billed per access minute to each Switched Access Service Customer.
2. When the Customer reports interstate and intrastate use of Switched Access Service, the Carrier Common Line charges will be billed only to intrastate.
3. All Switched Access Service provided to the Customer will be subject to Carrier Common Line charges.

**ACCESS SERVICE TARIFF**

Issued: August 19, 2003

Effective: September 19, 2003

**3. SWITCHED ACCESS SERVICE**

**3.3. SWITCHED ACCESS RATE CATEGORIES (CONT'D)**

**3.3.2. TRANSPORT**

The Transport rate category provides for transmission facilities between the Customer's premises and the End Office or Access Tandem switch(es) where the Customer's traffic is switched to originate or terminate its communications.

Switched Transport is a two-way voice-frequency transmission path which may consist of an Entrance Facility (EF), Direct-Trunked Transport (DTT) Facility or Common Transport.

**A. Common Transport**

The Common Transport rate category provides for transmission facilities between the Company's End Office and an alternate tandem provider's network.

**1. Transport Termination**

The Transport Termination element includes the non-distance sensitive portion of Switched Transport and is assessed on a per-access-minute-of-use basis.

**2. Transport Mileage**

The Transport Mileage element includes the distance sensitive portion of Switched Transport and is assessed on a per-access-minute-of-use-per-mile basis.

**ACCESS SERVICE TARIFF**

Issued: August 19, 2003

Effective: September 19, 2003

**3. SWITCHED ACCESS SERVICE**

**3.3. SWITCHED ACCESS RATE CATEGORIES (CONT'D)**

**3.3.2. TRANSPORT (CONT'D)**

**B. Direct-Trunked Transport**

**1. Voice Grade/DSO Facility**

A Voice Grade facility is an electrical communications path which provides voice-frequency transmission in the nominal frequency range of 300 to 3000 HZ and may be terminated two-wire or four-wire.

**2. DS1 Facility**

A DS1 facility is capable of transmitting electrical signals at a nominal 1.544 Mbps, with the capability to channelize up to 24 voice-frequency transmission paths.

**3. DS3 Facility**

A DS3 facility is capable of transmitting electrical signals at a nominal 44.736 Mbps, with the capability to channelize up to 672 voice-frequency transmission paths.

**C. Local Channel/Entrance Facility**

The Local Channel/Entrance Facility provides a communications path between the Customer's premises and the serving wire center of that premises. The Local Channel/Entrance Facility rate is assessed a monthly fixed charge based on the capacity (e.g., Voice Grade/DS0, DS1, or DS3) ordered.

**ACCESS SERVICE TARIFF**Issued: August 19, 2003Effective: September 19, 2003**3. SWITCHED ACCESS SERVICE****3.3. SWITCHED ACCESS RATE CATEGORIES (CONT'D)****3.3.3. LOCAL SWITCHING**

The Local Switching rate category provides the local end office switching and end user termination functions necessary to complete the transmission of Switched Access communications to and from the end users served by the Company's End Office.

**A. Local Switching Rate Element**

The Local Switching rate element provides local dial switching for Feature Groups B and D.

**B. Common Trunk Port**

The end office Common Trunk Port rate provides for the termination of common transport trunks in shared end office ports. The end office Common Trunk Port rate is assessed on a per-MOU basis to all trunkside originating and terminating access minutes utilizing tandem routing to an end office.

**C. Dedicated Trunk Port**

The end office Dedicated Trunk Port rate provides for the termination of a trunk to a dedicated trunk port in an end office. The rate is assessed per month for each FG trunk in service directly routed (via DTT) between the SWC and the end office.

**D. Interconnection Charge**

The Interconnection Charge shall be assessed upon all Customers interconnecting with the Company's switched access network. Interconnection is applicable to all switched access originating and terminating minutes of use.

**ACCESS SERVICE TARIFF**

Issued: December 21, 2007

Effective: January 7, 2008

**3. SWITCHED ACCESS SERVICE**

**3.3. SWITCHED ACCESS RATE CATEGORIES (CONT'D)**

**3.3.4. 8XX TOLL-FREE ACCESS SERVICE**

8XX Toll-Free Access Service is a service offering originating trunk side Switched Access Service. The service provides for the forwarding of end user dialed 8XX calls to a Company Service Switching Point which will initiate a query to the database to perform the Customer identification and delivery functions. The call is forwarded to the appropriate Customer based on the dialed 8XX number. In addition, the Customer has the option of selecting the 8XX Optional Features Package.

**1. Customer Identification Charge**

The 8XX Toll-Free Access Service Customer Identification Charge applies for the identification and delivery of the appropriate Customer. The charge is assessed to the Customer on a per query basis and may include an area of service which may range from a single NPA-NXX to an area consisting of all LATAs and NPAs in the State of Colorado. The 8XX Customer Identification Charge is set forth in Section 4.

(D)

(D)

(D)

(D)

**ACCESS SERVICE TARIFF**Issued: December 21, 2007Effective: January 7, 2008**3. SWITCHED ACCESS SERVICE****3.4. SWITCHED ACCESS RATES AND CHARGES****3.4.1. SERVICE IMPLEMENTATION**

	<b>NONRECURRING CHARGE</b>	
A. Installation Charge, Per Location, Per Order		
1. First Trunk	\$0.00	
2. Each Subsequent Trunk	0.00	

**3.4.2. CARRIER COMMON LINE**

	<b>RECURRING RATE PER MOU</b>	
A. Originating	\$0.0090200	(R)
B. Terminating	0.0090200	(R)

**3.4.3. TRANSPORT**

A. Common Transport		
1. Transport Termination	\$0.0003760	
2. Transport Mileage, per mile	0.0000340	

**ACCESS SERVICE TARIFF**

Issued: August 19, 2003

Effective: September 19, 2003

**3. SWITCHED ACCESS SERVICE****3.4. SWITCHED ACCESS RATES AND CHARGES (CONT'D)****3.4.3. SWITCHED TRANSPORT (CONT'D)**

## B. Local Channel/Entrance Facility

	<b>NONRECURRING CHARGE</b>		<b>MONTHLY RATE</b>
	<b><u>FIRST</u></b>	<b><u>ADD'L</u></b>	
1. VG/DS0	\$0.00	\$0.00	ICB
2. DS1	0.00	0.00	ICB
3. DS3	0.00	0.00	ICB

## C. Direct Trunked Transport

	<b>NONRECURRING <u>CHARGE</u></b>	<b>MONTHLY <u>RATE</u></b>
	1. VG	
• Per Mile	-	ICB
• Termination	\$ 0.00	ICB
2. DS0		
• Per Mile	-	ICB
• Termination	0.00	ICB
3. DS1		
• Per Mile	-	ICB
• Termination	0.00	ICB
4. DS3		
• Per Mile	-	ICB
• Termination	0.00	ICB

**ACCESS SERVICE TARIFF**

Issued: December 21, 2007

Effective: January 7, 2008

**3. SWITCHED ACCESS SERVICE****3.4. SWITCHED ACCESS RATES AND CHARGES (CONT'D)****3.4.4. LOCAL SWITCHING**

## A. Local Switching

**RECURRING RATE  
PER MOU**

1. Originating Access	\$0.0120650	(R)
2. Terminating Access	0.0120650	(R)
3. Common Trunk Port	0.0013000	
4. Interconnection Charge	0.0000000	

**MONTHLY RATE**

## 5. Dedicated Trunk Port

## a. DS0/VG, per trunk

ICB

## b. DS1, per trunk

ICB

**3.4.5. 8XX TOLL-FREE ACCESS****RECURRING RATE  
PER QUERY**

## A. 8XX Toll-Free Access Service

## 1. Customer Identification Charge

\$0.0035000

(D)

(D)