

Issued: February 10, 2006

Effective: February 17, 2006

**THIS TARIFF REPLACES COMCAST BUSINESS COMMUNICATIONS
ACCESS TARIFF B.P.U. – N.J. NO. 4 IN ITS ENTIRETY**

TARIFF SCHEDULES

Applicable to

ACCESS SERVICE

of

COMCAST BUSINESS COMMUNICATIONS, LLC

within the

STATE OF NEW JERSEY

ISSUED BY:
JOHN SULLIVAN, VICE PRESIDENT
COMCAST BUSINESS COMMUNICATIONS, LLC
1500 MARKET STREET
PHILADELPHIA, PA 19102

Issued: February 10, 2006

Effective: February 17, 2006

TABLE OF CONTENTS

	<u>PAGE NO.</u>
TITLE PAGE.....	1
TABLE OF CONTENTS	1

SECTION 1. APPLICATION OF TARIFF

1.1. GENERAL	1
1.2. TARIFF REVISION SYMBOLS	1
1.3. DEFINITIONS	2
1.4. EXPLANATION OF ABBREVIATIONS	7

Issued: February 10, 2006

Effective: February 17, 2006

TABLE OF CONTENTS

PAGE NO.

SECTION 2. GENERAL REGULATIONS

2.1.	UNDERTAKING OF THE COMPANY	1
2.1.1.	Scope.....	1
2.1.2.	Shortage of Facilities	1
2.1.3.	Terms and Conditions	1
2.1.4.	Provision of Equipment and Facilities	4
2.1.5.	Liability of the Company	6
2.1.6.	Discontinuance of Service for Cause	8
2.2.	OBLIGATIONS OF THE CUSTOMER	9
2.2.1.	Customer Premises Provisions.....	9
2.2.2.	Liability of the Customer	9
2.2.3.	Jurisdictional Reporting Requirements.....	10
2.2.4.	Changes in Service Requested	14
2.2.5.	Notice to Company for Cancellation of Service	14
2.2.6.	Claims	14
2.2.7.	Transfers and Assignments	14
2.3.	CUSTOMER EQUIPMENT AND CHANNELS	15
2.3.1.	Interconnection of Facilities	15
2.3.2.	Inspection and Testing	15
2.4.	ORDERING, RATING AND BILLING OF ACCESS SERVICES WHERE MORE THAN ONE EXCHANGE COMPANY IS INVOLVED.....	16
2.5.	ALLOWANCE FOR INTERRUPTIONS IN SERVICE.....	16
2.5.1.	General.....	16
2.5.2.	Notification of Service-Affecting Activities.....	16
2.5.3.	Limitations on Allowances	17
2.5.4.	Use of Another Means of Communications.....	18
2.5.5.	Application of Credits for Interruptions in Service	18
2.6.	PRIVACY RULES	19
2.7.	APPLICATION OF RATES AND CHARGES	20
2.7.1.	Measuring Access Minutes	20
2.7.2.	Rates Based Upon Distance	21
2.7.3.	Nonrecurring Charges	22

Issued: February 10, 2006

Effective: February 17, 2006

TABLE OF CONTENTS

PAGE NO.

SECTION 2. GENERAL REGULATIONS (CONT'D)

2.8.	ACCESS SERVICE ORDER.....	23
2.8.1.	Ordering Requirements	23
2.8.2.	Access Service Order Intervals.....	24
2.8.3.	Access Order Modifications	26
2.8.4.	Cancellation of an Access Order.....	29
2.8.5.	Minimum Period	30
2.8.6.	Minimum Period Charge.....	30
2.9.	BILLING AND PAYMENT	31
2.9.1.	Taxes	31
2.9.2.	Claims and Disputes.....	32
2.9.3.	Payment of Deposits	33
2.9.4.	Advance Payments	33
2.10.	SPECIAL CONSTRUCTION.....	34
2.11.	NON-ROUTINE INSTALLATION	34

Issued: February 10, 2006

Effective: February 17, 2006

TABLE OF CONTENTS

PAGE NO.

SECTION 3. SWITCHED ACCESS SERVICE

3.1.	GENERAL	1
3.2.	PROVISION AND DESCRIPTION.....	1
3.2.1.	Feature Group B.....	1
3.2.2.	Feature Group D.....	1
3.2.3.	8XX Toll-Free Access Service	1
3.3	SWITCHED ACCESS RATE CATEGORIES.....	2
3.3.1.	Carrier Common Line	3
3.3.2.	Transport	4
3.3.3.	Local Switching	6
3.3.4.	8XX Toll Free Access Service.....	7
3.4.	SWITCHED ACCESS RATES AND CHARGES	8
3.4.1.	Service Implementation	8
3.4.2.	Carrier Common Line	8
3.4.3.	Transport	8
3.4.4.	Local Switching	10
3.4.5.	8XX Toll-Free Access	10

Issued: February 10, 2006

Effective: February 17, 2006

TABLE OF CONTENTS

PAGE NO.

SECTION 4. SPECIAL ACCESS SERVICE

4.1. GENERAL 1

Issued: February 10, 2006

Effective: February 17, 2006

TABLE OF CONTENTS

PAGE NO.

SECTION 5. MISCELLANEOUS SERVICES

5.1.	PRESUBSCRIPTION	1
5.2.	UNAUTHORIZED PRIMARY INTEREXCHANGE CARRIER CHARGE	2
5.3.	SPECIAL ASSEMBLIES AND INDIVIDUAL CASE BASIS ARRANGEMENTS	2
5.4.	RATES AND CHARGES	3

Issued: February 10, 2006

Effective: February 17, 2006

INDEX

SECTION - PAGE

8XX Toll - Free Access	3 - 10
8XX Toll Free Access Service.....	3 - 7
8XX Toll - Free Access Service	3 - 1
Access Order Modifications	2 - 26
Access Service Order Intervals.....	2 - 24
Access Service Order	2 - 23
Advance Payments.....	2 - 33
Allowance for Interruptions in Service.....	2 - 16
Application Of Credits For Interruptions In Service	2 - 18
Application of Rates and Charges.....	2 - 20
Billing and Payment.....	2 - 31
Cancellation Of An Access Order.....	2 - 29
Carrier Common Line	3 - 3
Carrier Common Line	3 - 8
Changes In Service Requested.....	2 - 14
Claims	2 - 14
Claims And Disputes	2 - 32
Customer Equipment and Channels.....	2 - 15
Customer Premises Provisions.....	2 - 9
Definitions.....	1 - 2
Discontinuance Of Service For Cause	2 - 8
Explanation of Abbreviations	1 - 7
Feature Group B	3 - 1
Feature Group D	3 - 1
Inspection And Testing.....	2 - 15
Interconnection Of Facilities.....	2 - 15
Jurisdictional Reporting Requirements.....	2 - 10
Liability Of The Company	2 - 6
Liability Of The Customer.....	2 - 9
Limitations On Allowances	2 - 17
Local Switching	3 - 10
Local Switching	3 - 6

Issued: February 10, 2006

Effective: February 17, 2006

INDEX

SECTION - PAGE

Measuring Access Minutes	2 - 20
Minimum Period Charge.....	2 - 30
Minimum Period	2 - 30
Nonrecurring Charges	2 - 22
Non - Routine Installation.....	2 - 34
Notice To Company For Cancellation Of Service.....	2 - 14
Notification Of Service - Affecting Activities.....	2 - 16
Obligations of the Customer	2 - 9
Ordering Requirements.....	2 - 23
Ordering, Rating and Billing of Access Services Where More than One Exchange Company is Involved	2 - 16
Payment Of Deposits	2 - 33
Presubscription.....	5 - 1
Provision and Description.....	3 - 1
Provision Of Equipment And Facilities	2 - 4
Rates and Charges.....	5 - 3
Rates Based Upon Distance	2 - 21
Scope	2 - 1
Service Implementation	3 - 8
Shortage Of Facilities	2 - 1
Special Assemblies and Individual Case Basis Arrangements.....	5 - 2
Special Construction	2 - 34
Switched Access Rate Categories.....	3 - 2
Switched Access Rates and Charges.....	3 - 8
Tariff Revision Symbols	1 - 1
Taxes	2 - 31
Terms And Conditions.....	2 - 1
Transfers And Assignments.....	2 - 14
Transport	3 - 4
Transport	3 - 8
Unauthorized Primary Interexchange Carrier Charge	5 - 2
Undertaking of the Company.....	2 - 1
Use Of Another Means Of Communications	2 - 18

Issued: February 10, 2006

Effective: February 17, 2006

1. APPLICATION OF TARIFF

1.1. GENERAL

This tariff applies to intrastate Access Service supplied to customers for origination and termination of traffic to and from Central Office codes assigned to the Company.

The provision of Access Service is subject to existing regulations and terms and conditions specified in this Tariff as well as in the Company's other current Tariffs, and may be revised, added to, or supplemented by superseding issues.

In addition to the regulations and charges herein, this Tariff is subject to specific regulations as may be prescribed by the New Jersey Board of Public Utilities.

1.2. TARIFF REVISION SYMBOLS

Revisions to this Tariff are coded through the use of symbols. These symbols appear in the right hand margin of the page. The symbols and their meanings are as follows:

- (C) To signify changed listing, rule, or condition which may affect rates or charges.
- (D) To signify discontinued material, including listing, rate, rule or condition.
- (I) To signify increase.
- (N) To signify new material including listing, rate, rule or condition.
- (R) To signify reduction.
- (T) To signify change in wording of text but not change in rate, rule or condition.

Issued: February 10, 2006

Effective: February 17, 2006

1. APPLICATION OF TARIFF

1.3. DEFINITIONS

Access Code

A uniform code assigned by the Company to an individual customer. The code has the form 10XXX, 10XXXXXX, 950-0XXX, or 950-1XXX.

Access Minutes

The usage of exchange facilities in intrastate service for the purpose of calculating chargeable usage.

Access Tandem

A switching system that provides a traffic concentration and distribution function for originating or terminating traffic between end offices and a customer's premises.

Answer Supervision

The transmission of the switch trunk equipment supervisory signal (off-hook or on-hook) to the customer's point of termination as an indication that the called party has answered or disconnected.

Board

The New Jersey Board of Public Utilities.

B.P.U.

The New Jersey Board of Public Utilities.

Call

A customer attempt for which the complete address code is provided to the service end office.

Issued: February 10, 2006

Effective: February 17, 2006

1. APPLICATION OF TARIFF

1.3. DEFINITIONS (CONT'D)

Central Office

A local Company switching system where exchange service customer station loops are terminated for purposes of interconnection to each other and to trunks.

Channel

A communications path between two or more points of termination.

Common Carrier

Any individual, partnership, association, joint-stock company, trust, governmental entity or corporation engaged for hire in intrastate communication by wire or radio, between two or more exchanges.

Communications System

Denotes channels and other facilities which are capable of communications between terminal equipment provided by other than the Company.

Company

Comcast Business Communications, LLC

Issued: February 10, 2006

Effective: February 17, 2006

1. APPLICATION OF TARIFF

1.3. DEFINITIONS (CONT'D)

Customer

The person or legal entity that subscribes to service under this Tariff and is responsible for payment of tariffed charges for services furnished to the customer.

Customer Premises

The customer premises is all space in the same building occupied by a customer and all space occupied by the same customer in different buildings on contiguous property.

End Office Switch

A Company switching system where exchange service customer station loops are terminated for purposes of interconnection to each other and to trunks.

End User

Any customer of an intrastate telecommunications service that is not a Carrier or Common Carrier, except that a Carrier shall be deemed to be an End User when such Carrier uses a telecommunications service for administrative purposes. A person or entity that offers telecommunications service exclusively as a reseller shall be deemed to be an End User if all resale transmissions offered by such reseller originate on the premises of such reseller when making such service available to others, directly or indirectly.

Issued: February 10, 2006

Effective: February 17, 2006

1. APPLICATION OF TARIFF

1.3. DEFINITIONS (CONT'D)

Exchange

A group of lines in a unit generally smaller than a LATA established by the Company for the administration of communications service in a specified area. An Exchange may consist of one or more central offices together with the associated facilities used in furnishing communications service within that area.

Facilities

Denotes any cable, poles, conduit, carrier equipment, wire center distribution frames, central office switching equipment, etc., utilized to provide the service offered under this Tariff.

Local Access and Transport Area (LATA)

A geographic area established for the provision and administration of communications service. It encompasses one or more designated exchanges, which are grouped to serve common social, economic and other purposes.

Local Calling Area

A geographical area, as defined in the Company's local or general exchange service Tariff in which an End User may complete a call without incurring toll usage charges.

Message

A Message is a Call as defined above.

Point of Termination

The point of demarcation within a customer-designated premises at which the Company's responsibility for the provision of access service ends. The point of demarcation is the point of interconnection between Company communications facilities and customer-provided facilities as defined in Part 68 of the Federal Communications Commission's Rules and Regulations.

Issued: February 10, 2006

Effective: February 17, 2006

1. APPLICATION OF TARIFF

1.3. DEFINITIONS (CONT'D)

Presubscription

An arrangement whereby an End User may select and designate to the Company an Interexchange Carrier (IXC) it wishes to access, without an Access Code, for completing long distance calls. The selected IXC is referred as the End User's Primary Interexchange Carrier (PIC).

Serving Wire Center

The wire center from which the customer-designated premises normally obtains dial tone from the Company.

Trunk

A communications path connecting two switching systems in a network, used in the establishment of an end-to-end connection.

Trunk Group

A set of trunks which are traffic engineered as a unit for the establishment of connections between switching systems in which all of the communications paths are interchangeable.

Wire Center

A physical location in which one or more central offices, used for the provision of exchange services, are located.

Issued: February 10, 2006

Effective: February 17, 2006

1. APPLICATION OF TARIFF

1.4. EXPLANATION OF ABBREVIATIONS

ANI	-	Automatic Number Identification
BHMC	-	Busy Hour Minutes of Capacity
BPU	-	Board of Public Utilities
BP	-	Billing Percentage
CCSA	-	Common Channel Signaling Access
DTT	-	Direct Trunk Transport
EF	-	Entrance Facility
FCC	-	Federal Communications Commission
FGB	-	Feature Group B
FGD	-	Feature Group D
IC	-	Interexchange Carrier
ICB	-	Individual Case Basis
Mbps	-	Megabits per second
MOU	-	Minutes of Use
LATA	-	Local Access and Transport Area
NECA	-	National Exchange Carrier Association
NPA	-	Numbering Plan Area
PIC	-	Primary Interexchange Carrier
PIU	-	Percentage of Interstate Usage

Issued: February 10, 2006

Effective: February 17, 2006

2. GENERAL REGULATIONS

2.1. UNDERTAKING OF THE COMPANY

2.1.1. SCOPE

The Company undertakes to furnish Switched Access Service in accordance with the terms and conditions set forth in this Tariff.

2.1.2. SHORTAGE OF FACILITIES

All service is subject to the availability of suitable facilities. The Company reserves the right to limit the length of communications or to discontinue furnishing services when necessary because of the lack of transmission medium capacity or because of any causes beyond its control.

The furnishing of service under this tariff is subject to the availability on a continuing basis of all the necessary facilities and is limited to the capacity of the Company's facilities as well as facilities the Company may obtain from other carriers to furnish service from time to time as required at the sole discretion of the Company.

2.1.3. TERMS AND CONDITIONS

- A. Service is provided on the basis of a minimum period of three months for Switched Access. For the purpose of computing charges in this tariff, a month is considered to have 30 days.
- B. Customers may be required to enter into written service orders which shall contain or reference a specific description of the service ordered, the rates to be charged, the duration of the services, and the terms and conditions in this Tariff. Customers will also be required to execute any other documents as may be reasonably requested by the Company.
- C. In any action between the parties to enforce any provision of this Tariff, the prevailing party shall be entitled to recover its legal fees and court costs from the non-prevailing party in addition to other relief a court may award.
- D. The Company shall comply with all rules and regulations issued by the B.P.U.. In addition, the Regulations set forth herein apply to all services offered throughout this Tariff unless otherwise specified in the service specific section of this Tariff.

Issued: February 10, 2006

Effective: February 17, 2006

2. GENERAL REGULATIONS

2.1. UNDERTAKING OF THE COMPANY

2.1.3. TERMS AND CONDITIONS (CONT'D)

E. Assignment or Transfer

All service provided under this Tariff is controlled by the Company and the customer may not transfer or assign the use of service without the express prior written consent of the Company. Such transfer or assignment only shall apply where there is no interruption of the use or location of service. All terms and conditions shall apply to all such permitted transferees or assignees, as well as all conditions of service.

F. Use of Service

The services the Company offers shall not be used for any unlawful purpose or for any use for which the customer has not obtained all required governmental approvals, authorization, licenses, consents and permits.

The Company may require applicants for service who intend to use the Company's offering for resale and/or for shared use to file a letter with the Company confirming that their use of the Company's offerings complies with relevant laws and regulations, policies, orders and decisions.

The Company may require a customer to immediately shut down its transmission if such transmission is causing interference to others.

A customer, joint user, or authorized user may not assign, or transfer in any manner, the service or any rights associated with the service without the express prior written consent of the Company. The Company will only permit a customer to transfer its existing service to another entity if the existing customer has paid all charges owed to the Company for regulated access services. All terms and conditions shall apply to all such permitted transferees or assignees, as well as all conditions of service.

Recording of telephone conversations of service provided by the Company is prohibited except as authorized by applicable federal, state and local laws.

G. Ownership of Facilities

The customer obtains no property right or interest in the use of any specific type of facility, service, equipment, number, process, or code. All right, title and interest to such items remain, at all times, solely with the Company.

Issued: February 10, 2006

Effective: February 17, 2006

2. GENERAL REGULATIONS

2.1. UNDERTAKING OF THE COMPANY

2.1.3. TERMS AND CONDITIONS (CONT'D)

H. Interconnection

The Company will provide for interconnection with other carriers in accordance with the rules and regulations promulgated by the B.P.U..

I. Service may be terminated upon written notice to the customer if:

1. The customer is using the service in violation of this tariff; or
2. The customer is using the service in violation of the law.

J. This tariff shall be interpreted and governed by the laws of the state of New Jersey without regard for its choice of laws provision

Issued: February 10, 2006

Effective: February 17, 2006

2. GENERAL REGULATIONS

2.1. UNDERTAKING OF THE COMPANY (CONT'D)

2.1.4. PROVISION OF EQUIPMENT AND FACILITIES

- A The Company shall use reasonable efforts to make available services to a customer on or before a particular date, subject to the provisions of and compliance by the customer with, the regulations contained in this tariff. The Company does not guarantee availability by any such date and shall not be liable for any delays in commencing service to any customer.
- B. The Company shall use reasonable efforts to maintain facilities and equipment that it furnishes to the customer. The customer may not, nor may customer permit others to, rearrange, disconnect, remove, attempt to repair, or otherwise interfere with any of the facilities or equipment installed by the Company, except upon the written consent of the Company.
- C. The Company may substitute, change or rearrange any equipment or facility at any time and from time to time, but shall not thereby alter the technical parameters of the service provided the customer, without the prior consent of the customer, which shall not be unreasonably withheld.
- D. Equipment the Company provides or installs at the customer premises for use in connection with the services the Company offers shall not be used for any purpose other than that for which the Company provided it.
- E. The customer shall be responsible for the payment of service charges as set forth herein for visits by the Company's agents or employees to the premises of the customer when the service difficulty or trouble report results from the use of equipment or facilities provided by any party other than the Company, including but not limited to the customer.

Issued: February 10, 2006

Effective: February 17, 2006

2. GENERAL REGULATIONS

2.1. UNDERTAKING OF THE COMPANY (CONT'D)

2.1.4. PROVISION OF EQUIPMENT AND FACILITIES

- F. The Company shall not be responsible for the installation, operation, or maintenance of any Customer provided communications equipment. Where such equipment is connected to the facilities furnished pursuant to this tariff, the responsibility of the Company shall be limited to the furnishing of facilities offered under this tariff and to the maintenance and operation of such facilities. Subject to this responsibility, the Company shall not be responsible for:
1. The transmission of signals by Customer provided equipment or for the quality of, or defects in, such transmission; or
 2. The reception of signals by Customer-provided equipment.
- G. Service is offered subject to the availability of facilities and provision of this Tariff. The Company's obligation to furnish facilities and service is dependent upon its ability to secure and retain, without unreasonable expense, suitable facilities from the underlying carrier, if an underlying carrier is involved.
- H. The Company shall not be required to furnish, or continue to furnish, facilities or service where the circumstances are such that the proposed use of the facilities or service would tend to adversely affect the Company's property, service or economic conditions.

Issued: February 10, 2006

Effective: February 17, 2006

2. GENERAL REGULATIONS

2.1. UNDERTAKING OF THE COMPANY (CONT'D)

2.1.5. LIABILITY OF THE COMPANY

- A. The liability of the Company for damages arising out of the furnishing of its Services, including but not limited to mistakes, omissions, interruptions, delays, or errors, or other defects, representations, or use of these services or arising out of the failure to furnish the service, whether caused by acts or omission, shall be limited to the extension of allowances for interruption as set forth in Section 2.5. The extension of such allowances for interruption shall be the sole remedy of the Customer and the sole liability of the Company. The Company will not be liable for any direct, indirect, incidental, special, consequential, exemplary or punitive damages to Customer as a result of any Company service, equipment or facilities, or the acts or omissions or negligence of the Company's employees or agents.
- B. The Company shall not be liable for any delay or failure of performance or equipment due to causes beyond its control, including but not limited to: acts of God, fire, flood, explosion or other catastrophes; any law, order, regulation, direction, action, or request of the United States Government, or of any other local governments having or claiming jurisdiction over the Company, or of any department, agency, commission, bureau, corporation, or other instrumentality of any one or more of these federal, state, or local governments, or of any civil or military authority; national emergencies; insurrections; riots; wars; unavailability of rights-of-way or materials; or strikes, lockouts, work stoppages, or other labor difficulties.
- C. The Company shall not be liable for (a) any act or omission of any entity furnishing to the Company or to the Company's Customers facilities or equipment used for interconnection with Access and Interconnection Services; or (b) for the acts or omissions of common carriers or warehousemen
- D. The Company shall not be liable for any damages or losses due to the fault or negligence of the Customer or due to the failure or malfunction of Customer-provided equipment or facilities.

Issued: February 10, 2006

Effective: February 17, 2006

2. GENERAL REGULATIONS

2.1. UNDERTAKING OF THE COMPANY

2.1.5. LIABILITY OF THE COMPANY (CONT'D)

- E. The Company does not guarantee nor make any warranty with respect to installations it provides for use in an explosive atmosphere. The Customer indemnifies and holds the Company harmless from any and all loss, claims, demands, suits, or other action, or any liability whatsoever, whether suffered, made, instituted, or asserted by any other party or person(s), and for any loss, damage, or destruction of any property, whether owned by the Customer or others, caused or claimed to have been caused directly or indirectly by the installation, operation, failure to operate, maintenance, removal presence, condition, location, or use of any installation so provided. The Company reserves the right to require each Customer to sign an agreement acknowledging acceptance of the provisions of this Section 2.1.5.E as a condition precedent to such installations.
- F. The Company is not liable for any defacement of or damage to Customer premises resulting from the furnishing of services or equipment on such Premises or the installation or removal thereof, unless such defacement or damage is caused by negligence or willful misconduct of the Company's agents or employees.
- G. The Company shall be indemnified, defended, held harmless by the Customer against any claim, loss or damage arising from Customer's use of services, involving claims for libel, slander, invasion of privacy, or infringement of copyright arising from the Customer's own communications.
- H. The entire liability for any claim, loss, damage or expense from any cause whatsoever shall in no event exceed sums actually paid Company by Customer for the specific services giving rise to the claim. No action or proceeding against the Company shall be commenced more than one year after the service is rendered.
- I. The Company makes no warranties or representations, express or implied either in fact or by operation of law, statutory or otherwise, including warranties of merchantability or fitness for a particular use, except those expressly set forth herein.

Issued: February 10, 2006

Effective: February 17, 2006

2. GENERAL REGULATIONS

2.1. UNDERTAKING OF THE COMPANY (CONT'D)

2.1.6 DISCONTINUANCE OF SERVICE FOR CAUSE

- A. Upon nonpayment of any amounts owing to the Company, the Company may, by giving 24 hours prior written notice to the customer, discontinue or suspend service without incurring any liability.
- B. Upon violation of any of the other material terms or conditions for furnishing service the Company may, by giving 24 hours prior notice in writing to the customer, discontinue or suspend service without incurring any liability if such violation continues during that period.
- C. Upon condemnation of any material portion of the facilities used by the Company to provide service to a customer or if a casualty renders all or any material portion of such facilities inoperable beyond feasible repair, the Company, by notice to the customer, may discontinue or suspend service without incurring any liability.
- D. Upon the customer's insolvency, assignment for the benefit of creditors, filing for bankruptcy or reorganization, or failing to discharge an involuntary petition within the time permitted by law, the Company may immediately discontinue or suspend service without incurring any liability.
- E. Upon any governmental prohibition or required alteration of the services to be provided or any violation of an applicable law or regulation, the Company may immediately discontinue service without incurring any liability.
- F. In the event of fraudulent use of the Company's network, the Company may without notice suspend or discontinue service. The customer will be liable for all related costs. The customer will also be responsible for payment of any reconnection charges.
- G. Upon the Company's discontinuance of service to the customer under 2.1.6.A. or 2.1.6.B., the Company, in addition to all other remedies that may be available to the Company at law or in equity or under any other provision of this Tariff, may declare all future monthly and other charges which would have been payable by the customer during the remainder of the term for which such services would have otherwise been provided to the customer to be immediately due and payable (discounted to present value at six percent).

Issued: February 10, 2006

Effective: February 17, 2006

2. GENERAL REGULATIONS

2.2. OBLIGATIONS OF THE CUSTOMER

2.2.1. CUSTOMER PREMISES PROVISIONS

- A. The customer shall provide the personnel, power and space required to operate all facilities and associated equipment installed on the premises of the customer.
- B. The customer shall be responsible for providing Company personnel access to premises of the customer at any reasonable hour for the purpose of testing the facilities or equipment of the Company.

2.2.2. LIABILITY OF THE CUSTOMER

- A. The customer will be liable for damages to the facilities of the Company and for all incidental and consequential damages caused by the negligent or intentional acts or omissions of the customer, its officers, employees, agents, invitees, or contractors where such acts or omissions are not the direct result of the Company's negligence or intentional misconduct.
- B. To the extent caused by any negligent or intentional act of the customer as described in A., preceding, the customer shall indemnify, defend and hold harmless the Company from and against all claims, actions, damages, liabilities, costs and expenses, including reasonable attorneys' fees, for (1) any loss, destruction or damage to property of any third party, (2) the death of or injury to persons, including, but not limited to, employees or invitees of either party, and (3) any liability incurred by the Company to any third party pursuant to this or any other price list or tariff of the Company, or otherwise, for any interruption of, interference to, or other defect in any service provided by the Company to such third party.
- C. The customer shall not assert any claim against any other customer or user of the Company's services for damages resulting in whole or in part from or arising in connection with the furnishing of service under this Tariff including but not limited to mistakes, omissions, interruptions, delays, errors or other defects or misrepresentations, whether or not such other customer or user contributed in any way to the occurrence of the damages, unless such damages were caused solely by the negligent or intentional act or omission of the other customer or user and not by any act or omission of the Company. Nothing in this Tariff is intended either to limit or to expand customer's right to assert any claims against third parties for damages of any nature other than those described in the preceding sentence.

Issued: February 10, 2006

Effective: February 17, 2006

2. GENERAL REGULATIONS

2.2. OBLIGATIONS OF THE CUSTOMER (CONT'D)

2.2.3. JURISDICTIONAL REPORTING REQUIREMENTS

- A. For Feature Group B Switched Access Service(s) for both originating and terminating usage, a projected Percentage of Interstate Usage (PIU) must be provided by the customer to the Company. When a customer orders Feature Group B Switched Access Service, the customer shall state, in its order, the projected PIU factor for each Feature Group B Switched Access Service group ordered. The formula for developing PIU is as follows in C., following.
- B. For Feature Group D Switched Access Service(s), the Company, where jurisdiction can be determined from call detail, will determine the PIU as follows:
 - 1. For originating access minutes, the PIU will be developed on a monthly basis, by end office trunk group, by dividing the measured interstate originating access minutes (the access minutes where the calling number is in one state and the called number is in another state) by the total originating access minutes.
 - 2. For terminating access minutes, the customer has the option to provide the Company with a projected PIU factor. Customers who provide a PIU factor shall supply the Company with an interstate percentage of the Feature Group D terminating access minutes for each account to which the customer may terminate traffic. Should the customer not supply a terminating PIU factor, the data used by the Company to develop the PIU for originating access minutes will be used to develop the PIU for such terminating access minutes.

When a customer orders Feature Group D Switched Access Service, the customer shall supply a projected PIU for each end office trunk group involved to be used in the event that originating call detail is insufficient to determine the jurisdiction of the usage. For purposes of developing the PIU, the customer shall utilize the same considerations as those set forth in C., following.

Issued: February 10, 2006

Effective: February 17, 2006

2. GENERAL REGULATIONS

2.2. OBLIGATIONS OF THE CUSTOMER

2.2.3. JURISDICTIONAL REPORTING REQUIREMENTS (CONT'D)

C. Where the call detail data is insufficient to develop jurisdiction, the customer must provide the Company with a PIU using the following steps:

1. For purposes of developing the PIU, the customer shall consider every call that enters the customer's network at a point within the same state as the state where the called station is located to be intrastate and every call that enters the customer's network at a point in a state different from the state in which the called station is located to be interstate.
2. The Company will designate the number obtained by subtracting the PIU from 100 ($100 - \text{projected interstate percentage} = \text{intrastate percentage}$) as the projected intrastate percentage of use.
3. A whole number percentage will be used by the Company to apportion the usage, monthly recurring, and/or nonrecurring charges between interstate and intrastate until a revised report is received.

D. The projected interstate percentage of use will be used to determine the charges as follows:

The number of access minutes for a trunk group will be multiplied by the projected interstate percentage of use to determine the interstate access minutes. (i.e., number of access minutes x projected interstate percentage of use = interstate access minutes). The number of interstate access minutes so determined will be subtracted from the total number of access minutes (i.e., number of access minutes - interstate access minutes = intrastate access minutes). The intrastate access minutes for the group will be billed as set forth in Section 3., following.

Issued: February 10, 2006

Effective: February 17, 2006

2. GENERAL REGULATIONS

2.2. OBLIGATIONS OF THE CUSTOMER

2.2.3. JURISDICTIONAL REPORTING REQUIREMENTS (CONT'D)

- E. Effective on the first of January, April, July and October of each year, the customer may update the jurisdictional reports that require a projected interstate percentage. The customer shall forward to the Company, to be received no later than 20 calendar days after the first of each such month, a revised report showing the interstate percentage of use for the past three months ending the last day of December, March, June and September, respectively, for each service arranged for interstate and intrastate use. Except as set forth in B., preceding, where jurisdiction can be determined from the recorded message detail, the revised report will serve as the basis for the next three months billing and will be effective on the bill date in the following month (i.e., February, May, August, and November) for that service. No prorating or back billing will be done based on the report. If the customer does not supply the report, the Company will assume the percentage to be the same as that provided in the last quarterly report. For those cases in which a quarterly report has never been received from the customer, the Company will assume the percentage to be the same as that provided in the order for service as set forth in A., preceding.
- F. The customer reported projected interstate percentage of use as set forth in A., above will be used for the apportionment of any monthly rates or nonrecurring charges associated with Feature Groups B or D Switched Access Service until the end of the quarter during which the service was activated. Thereafter, a projected interstate percentage for such apportionment will be developed quarterly by the Company based on the data used to develop the projected interstate percentage of use as set forth in A., preceding. Where call detail is insufficient to make such a determination, the customer will be requested to project an interstate percentage of use to be used by the Company for such apportionment.

Issued: February 10, 2006

Effective: February 17, 2006

2. GENERAL REGULATIONS

2.2. OBLIGATIONS OF THE CUSTOMER

2.2.3. JURISDICTIONAL REPORTING REQUIREMENTS (CONT'D)

- G. The customer shall keep sufficient detail from which the percentage of interstate use can be ascertained and upon request of the Company make the records available for inspection. Such a request will be initiated by the Company no more than once per year. The customer shall supply the data within 30 calendar days of the Company request.
- H. The customer may provide an additional percentage of interstate use for Common Transport and End Office/Local Switching subject to the reporting requirements previously listed in this section. The percentage of interstate use may be provided per individual facility or at the billing account level. Should the customer not provide a percentage of interstate use, the Company will use the reported Feature Group B or Feature Group D aggregated percentage of interstate use.
- I. In the sole discretion of the Company, all or any portion of the jurisdictional reporting requirements set out above may be waived.

Issued: February 10, 2006

Effective: February 17, 2006

2. GENERAL REGULATIONS

2.2. OBLIGATIONS OF THE CUSTOMER (CONT'D)

2.2.4. CHANGES IN SERVICE REQUESTED

If the customer makes or requests material changes in circuit engineering, equipment specifications, service parameters, premises locations, or otherwise materially modifies any provision of the application for service, the customer's installation fees shall be adjusted according to the terms and conditions set forth in Section 2.8, following.

2.2.5. NOTICE TO COMPANY FOR CANCELLATION OF SERVICE

Customers desiring to terminate service shall provide the Company 30 day's written notice of their desire to terminate service.

2.2.6. CLAIMS

With respect to any service or facility provided by the Company, the customer shall indemnify, defend and hold harmless the Company from and against all claims, actions, damages, liabilities, costs and expenses, including reasonable attorney fees for:

- A. Any loss, destruction or damage to property of the Company or any third party, or the death or injury to persons, including, but not limited to, employees or invitees of either party, to the extent caused by or resulting from the negligent or intentional act or omission of the customer, its employees, agents, representatives or invitees; or
- B. Any claim, loss, damage, expense or liability for infringement of any copyright, patent, trade secret, or any proprietary or intellectual property right of any third party, arising from any act or omission by the customer, including, without limitation, use of Company services and facilities in a manner not contemplated by the agreement between the customer and the Company.

2.2.7 TRANSFERS AND ASSIGNMENTS

The customer may not assign or transfer its rights or duties in connection with the services and facilities provided by the Company without the written consent of the Company.

Issued: February 10, 2006

Effective: February 17, 2006

2. GENERAL REGULATIONS

2.3. CUSTOMER EQUIPMENT AND CHANNELS

2.3.1. INTERCONNECTION OF FACILITIES

In order to protect the Company's facilities and personnel and the services furnished to other customers by the Company from potentially harmful effects, the signals applied to the Company's service shall be such as not to cause damage to the facilities of the Company. Any special interface equipment necessary to achieve the compatibility between facilities of the Company and the channels or facilities of others shall be provided at the customer's expense.

- A. The Company may, upon notification to the customer, at a reasonable time, make such tests and inspections as may be necessary to determine that the customer is complying with the Company's requirements for the installation, operation and maintenance of customer-provided equipment and for the wiring of the connection of customer equipment to Company-owned facilities.
- B. If the protective requirements in connection with customer-provided equipment are not being complied with, the Company may take such action as necessary to protect its facilities and personnel and will promptly notify the customer by registered mail in writing of the need for protective action. In the event that the customer fails to advise the Company within 10 days after such notice is received or within the time specified in the notice that corrective action has been taken, the Company may take whatever additional action is deemed necessary, including the suspension of service, to protect its facilities and personnel from harm. The Company will, upon request 24 hours in advance, provide the customer with a statement of technical parameters that the customer's equipment must meet.

2.3.2. INSPECTION AND TESTING

- A. Upon suitable notification to the Customer, and at a reasonable time, the Company may make such tests and inspections as may be necessary to determine that the Customer is complying with the requirements set forth in Section 2.3 for the installation, operation, and maintenance of Customer-provided facilities, equipment, and wiring in the connection of Customer-provided facilities and equipment to Company-owned facilities and equipment.
- B. If the protective requirements for Customer-provided equipment are not being complied with, the Company may take such action as it deems necessary to protect its facilities, equipment, and personnel. The Company will notify the Customer promptly if there is any need for further corrective action. Within ten days of receiving this notice, the Customer must take this corrective action and notify the Company of the action taken. If the Customer fails to do this, the Company may take whatever additional action is deemed necessary, including the suspension of service, to protect its facilities, equipment and personnel from harm.

Issued: February 10, 2006

Effective: February 17, 2006

2. GENERAL REGULATIONS

2.4. ORDERING, RATING AND BILLING OF ACCESS SERVICES WHERE MORE THAN ONE EXCHANGE COMPANY IS INVOLVED

The Company accepts and adheres to the Ordering and Billing Forum guidelines, Multiple Exchange Carrier Access Billing (MECAB) and Multiple Exchange Carrier Ordering and Design (MECOD).

2.5. ALLOWANCE FOR INTERRUPTIONS IN SERVICE

2.5.1. GENERAL

- A. A credit allowance will be given when service is interrupted, except as specified in 2.5.3, following. A service is interrupted when it becomes inoperative to the customer; e.g., the customer is unable to transmit or receive because of a failure of a component furnished by the Company under this tariff.
- B. An interruption period begins when the customer reports a service, facility or circuit to be inoperative and, if necessary, releases it for testing and repair. An interruption period ends when the service, facility, or circuit is operative.
- C. If the customer reports a service, facility, or circuit to be interrupted but declines to release it for testing and repair, the service, facility, or circuit is considered to be impaired but not interrupted. No credit allowances will be made for a service, facility, or circuit considered by the Company to be impaired.

2.5.2. NOTIFICATION OF SERVICE-AFFECTING ACTIVITIES

The Company will provide the customer reasonable notification of service-affecting activities that may occur in normal operation of its business. Such activities may include, but are not limited to, equipment or facilities additions, removals or rearrangements and routine preventative maintenance. Generally, such activities are not specific to an individual customer but affect many customers' services. No specific advance notification period is applicable to all service activities. The Company will work cooperatively with the customer to determine the reasonable notification requirements. With some emergency or unplanned service-affecting conditions, such as an outage resulting from cable damage, notification to the customer may not be possible.

Issued: February 10, 2006

Effective: February 17, 2006

2. GENERAL REGULATIONS

2.5. ALLOWANCE FOR INTERRUPTIONS IN SERVICE (CONT'D)

2.5.3. LIMITATIONS ON ALLOWANCES

No credit allowance will be made for any interruption in service:

- A. Due to the negligence of or noncompliance with the provisions of this Tariff by any person or entity other than the Company, including but not limited to the customer or other common carriers connected to the service of the Company;
- B. Due to the failure of power, equipment, systems, connections or services not provided by the Company;
- C. Due to circumstances or causes beyond the control of the Company;
- D. During any period in which the Company is not given full and free access to its facilities and equipment for the purposes of investigating and correcting interruptions;
- E. During any period in which the customer continues to use the service on an impaired basis;
- F. During any period when the customer has released service to the Company for maintenance purposes or for implementation of a customer order for a change in service arrangements;
- G. That occurs or continues due to the customer's failure to authorize replacement of any element of special construction; and
- H. That was not reported to the Company within thirty (30) days of the date that service was affected.

Issued: February 10, 2006

Effective: February 17, 2006

2. GENERAL REGULATIONS

2.5. ALLOWANCE FOR INTERRUPTIONS IN SERVICE (CONT'D)

2.5.4. USE OF ANOTHER MEANS OF COMMUNICATIONS

If the customer elects to use another means of communications during the period of interruption, the customer must pay the charges for the alternative service used.

2.5.5. APPLICATION OF CREDITS FOR INTERRUPTIONS IN SERVICE

In case of an interruption to any service, allowance for the period of interruption, if not due to the negligence of the customer, shall be as follows:

- A. For Switched Access Service, no credit shall be allowed for an interruption of less than 24 hours. The customer shall be credited for an interruption of 24 hours or more at the rate of 1/30 of (a) any applicable monthly rates, or (b) the assumed minutes of use charge for each period of 24 hours or major fraction thereof that the interruption continues.
- B. The credit allowance(s) for an interruption or for a series of interruptions shall not exceed (a) any applicable monthly rates, or (b) the assumed minutes of use charge for the service interrupted in any one monthly billing period.

Issued: February 10, 2006

Effective: February 17, 2006

2. GENERAL REGULATIONS

2.6. PRIVACY RULES

Automatic Number Identification (ANI) derived information may be used only for billing, routing, screening, ensuring network performance, completing calls or performing, services directly related to the telephone caller's original call or transaction. Therefore, should the business that receives ANI information have an established customer relationship with the caller, the business may offer products or services to the caller that are directly related to the products or services previously purchased by the caller. The business that receives ANI information may not establish marketing lists or conduct ongoing market calls for unrelated products or services or sell the information derived from ANI (caller's name, address, telephone billing number, purchasing habits, etc.) to third parties unless it gets the prior written consent of the caller.

Issued: February 10, 2006

Effective: February 17, 2006

2. GENERAL REGULATIONS

2.7. APPLICATION OF RATES AND CHARGES

The regulations set forth in this section govern the application of rates for services contained in other sections of this Tariff.

2.7.1. MEASURING ACCESS MINUTES

Customer traffic to End Offices will be measured (i.e., recorded or assumed) by the Company at End Office switches. Originating and terminating calls will be measured (i.e., recorded or assumed) by the Company to determine the basis for computing chargeable access minutes. In the event the customer message detail is not available because the Company lost or damaged tapes or experienced recording system outages, the Company will estimate the volume of lost customer access minutes of use based on previously known values. Access minutes will be recorded to the nearest one second for any particular call. Access minutes or fractions thereof are accumulated over the billing period for each End Office and are then rounded up to the nearest access minute for each end office.

For originating calls over Feature Group B or D, usage measurement begins when the originating Feature Group B or D switch receives the first wink supervisory signal forwarded from the customer's point of termination.

The measurement of originating call usage ends when the originating Feature Group B or D switch receives disconnect supervision from either the originating end user's end office, indicating the originating end user has disconnected, or the customer's point of termination, whichever is recognized first by the switch.

For terminating calls over Feature Group B or D, the measurement of access minutes begins when the terminating Feature Group B or D switch receives answer supervision from the terminating end user's end office, indicating the terminating end user has answered.

The measurement of terminating call usage over Feature Group B or D ends when the terminating Feature Group B or D switch receives disconnect supervision from either the terminating end user's end office, indicating the terminating end user has disconnected, or the customer's point of termination, whichever is recognized first by the switch.

Issued: February 10, 2006

Effective: February 17, 2006

2. GENERAL REGULATIONS

2.7. APPLICATION OF RATES AND CHARGES (CONT'D)

2.7.2. RATES BASED UPON DISTANCE

Where the charges for service are specified based upon distance, the following rules apply:

- A. Distance between two points is measured as airline distance between the wire centers of the originating and terminating telephone lines. The wire center is a set of geographic coordinates, as referenced in National Exchange Carrier Association, Inc. Tariff F.C.C. No. 4, associated with each NPA-NXX combination (where NPA is the area code and NXX is the first three digits of a seven-digit telephone number). Except that, until the National Exchange Carrier Association, Inc. Tariff F.C.C. No. 4 is revised to include certain Company wire centers, the airline distance should be determined utilizing the "V" (vertical) and "H" (horizontal) coordinates as set forth in any applicable Company tariffs on file with the FCC.
- B. The airline distance between any two wire centers is determined as follows:
 1. Obtain the "V" and "H" coordinates for each wire center from the above referenced NECA tariff.
 2. Compute the difference between the "V" coordinates of the two wire centers; and the difference between the two "H" coordinates.
 3. Square each difference obtained in step (2) above.
 4. Add the square of the "V" difference and the square of the "H" difference obtained in step (3).
 5. Divide the sum of the squares by 10. Round to the next higher whole number if any fraction is obtained.
 6. Obtain the square root of the whole number result obtained above. Round to the next higher whole number if any fraction is obtained. This is the airline mileage.

Formula:

$$\sqrt{\frac{|v_1v_2|^2 + |h_1h_2|^2}{10}}$$

- C. The airline mileage is used to determine the Switched Access Service Common Mileage rates as set forth in Section 3.

Issued: February 10, 2006

Effective: February 17, 2006

2. GENERAL REGULATIONS

2.7. APPLICATION OF RATES AND CHARGES (CONT'D)

2.7.3. NONRECURRING CHARGES

Nonrecurring charges are onetime charges that apply for a specific work activity (i.e., installation or service rearrangements).

A. Installation of Service

Nonrecurring charges apply to each Access Service installed. For Switched Services ordered on a per trunk basis, the charge is applied per trunk. For Switched Services ordered on a busy hour minutes of capacity basis, the charge is also applied on a per trunk basis but the charge applies only when the capacity ordered requires the installation of an additional trunk(s).

B. Service Rearrangements

All changes to existing services other than changes involving administrative activities only will be treated as a discontinuance of the existing service and an installation of a new service. The nonrecurring charge described in A., preceding, will apply for this work activity. Moves that change the physical location of the point of termination are described below.

1. Moves Within the Same Building

When the move is to a new location within the same building, the charge for the move will be an amount equal to one half of the nonrecurring charge for the capacity affected. There will be no change in the minimum period requirements.

2. Moves to a Different Building

Moves to a different building will be treated as a discontinuance and start of service and all associated nonrecurring charges will apply. New minimum period requirements will be established for the new service. The customer will also remain responsible for satisfying all outstanding minimum period charges for the discontinued service.

Issued: February 10, 2006

Effective: February 17, 2006

2. GENERAL REGULATIONS

2.8. ACCESS SERVICE ORDER

2.8.1. ORDERING REQUIREMENTS

- A. A Switched Access Service Order is used by the Company to provide a customer Switched Access Service. When placing an order for Switched Access Service, the customer shall provide, at a minimum, the following information:
1. For Feature Group B Switched Access Service, the customer shall specify the number of trunks and the End Office when direct routing to the End Office is desired. When ordering FGB trunks to an End Office, the customer must also provide the Company an estimate of the amount of traffic to be generated to and/or from each End Office subtending an access tandem to assist the Company in the effort to project further facility requirements. In addition, the customer shall also specify for terminating only access, whether the trunks are to be arranged in trunk group arrangements or provided as single trunks.
 2. For Feature Group D Switched Access Service, the customer shall specify the number of busy hour minutes of capacity (BHMC) from the customer's premises to the End Office by Feature Group and by traffic type. This information is used to determine the number of transmission paths. The customer shall also specify the Common Transport and Local Switching options. Customers may, at their option, order FGD by specifying the number of trunks and the End Office when direct routing to the end office is desired and the Common Transport and Local Switching options desired. When a customer orders FGD in trunks, the customer is responsible to assure that sufficient access facilities have been ordered to handle its traffic. When ordering by trunk quantities rather than BHMC quantities to an end office, the customer must also provide the Company an estimate of the amount of traffic it will generate to and/or from each End Office to assist the Company in its own efforts to project further facility requirements.

Issued: February 10, 2006

Effective: February 17, 2006

2. GENERAL REGULATIONS

2.8. ACCESS SERVICE ORDER (CONT'D)

2.8.2. ACCESS SERVICE ORDER INTERVALS

Switched Access Service is provided with one of the following Service Date Intervals:

- Negotiated Interval
- Advance Order Interval

A. Negotiated Interval

The Company will negotiate a service date interval with the customer. The Company will offer a service date based on the type and quantity of Access Services the customer has requested. All services for which rates are applied on an individual case basis are provided with a Negotiated Interval.

The initial establishment of service where the customer is:

	MAXIMUM INTERVAL
1. Not yet provided with any FGB or FGD service in the LATA	6 months
2. Provided FGB or FGD service in the LATA	90 Days

Issued: February 10, 2006

Effective: February 17, 2006

2. GENERAL REGULATIONS

2.8. ACCESS SERVICE ORDER

2.8.2. ACCESS SERVICE ORDER INTERVALS (CONT'D)

B. Advance Order Interval

1. When placing an Access Order, a customer may request an Advance Order Interval for a service date of 12 to 24 months from the Application Date for the following services:
 - A minimum of 24 voice grade equivalent Access Service lines or trunks or 720 BHMCs
2. Orders for less than the minimum quantities will be accommodated under Negotiated Interval provisions.
3. Advance Order Interval Access Orders are subject to all ordering conditions of Negotiated Interval Access Orders except for the following:
4. A nonrefundable Advance Payment will be calculated as follows:
 - The minimum monthly charge for the minimum period plus the applicable Nonrecurring Charges for the services ordered.
5. This Advance Payment is due 10 working days from the date the Company confirms acceptance of the order, or on the Application Date, whichever date is the later date. If the Advance Payment is not received by such payment date, the order will be canceled.
6. When the Access Services are connected on the service date, the Advance Payment will be applied as a credit to the customer's billed service charges. When there has been a decrease in the number of services originally ordered, as described below, only the portion of the Advance Payment for services actually installed will be credited.
7. Cancellation or Partial Cancellation of an Advance Order Interval Access Order
 - a. When the customer cancels an Access Order, the order will be withdrawn. The Advance Payment will not be credited or refunded.
 - b. Any decrease in the number of ordered Access Services will be treated as a partial cancellation, and the portion of the Advance Payment for the services canceled will not be credited or refunded.

Issued: February 10, 2006

Effective: February 17, 2006

2. GENERAL REGULATIONS

2.8. ACCESS SERVICE ORDER (CONT'D)

2.8.3. ACCESS ORDER MODIFICATIONS

The customer may request a modification of its Access Order at any time prior to notification by the Company that service is available for the customer's use or prior to the service date, whichever is later.

Any increase in the number of Access Service lines, trunks or busy hour minutes of capacity or CCSA signaling connections will be treated as a new Access Order (for the increased amount only).

A. Service Date Change Charge

Access Order service dates for the installation of new services or rearrangements of existing services may be changed, but the new service date may not exceed the original service date by more than 30 calendar days. When, for any reason, the customer indicates that service cannot be accepted for a period not to exceed 30 calendar days, and the Company accordingly delays the start of service, a Service Date Change Charge will apply. If the customer requested service date is more than 30 calendar days after the original service date, the order will be canceled by the Company and reissued with the appropriate cancellation charges applied.

A Service Date Change Charge will apply, on a per order, per occurrence basis, for each service date changed. The applicable charge is found in E., following.

B. Partial Cancellation Charge

Any decrease in the number of ordered Access Service lines, trunks or busy hour minutes of capacity ordered with a Negotiated Interval Access Order will be treated as a partial cancellation and the charges as set forth in E., following, will apply. Partial cancellation charges do not apply to Advance Order Interval Access Orders.

Issued: February 10, 2006

Effective: February 17, 2006

2. GENERAL REGULATIONS

2.8. ACCESS SERVICE ORDER

2.8.3. ACCESS ORDER MODIFICATIONS (CONT'D)

C. Design Change Charge

The customer may request a design change to the service ordered. A design change is any change to an Access Order that requires engineering review. Design changes do not include a change of customer premises, end user premises, end office switch, or Feature Group type except for changes to Feature Group D. Changes of this nature will require the issuance of a new order and the cancellation of the original order with appropriate cancellation charges applied.

The Design Change Charge will apply on a per order, per occurrence basis, for each order requiring a design change. The applicable charge is found in E., following.

If a change of service date is required, the Service Date Change Charge will also apply.

D. Expedited Order Charge

When placing an Access Order for service(s), a customer may request a service date that is prior to the service date that has been negotiated by the Company and the customer. A customer may also request an earlier service date on a pending Negotiated or Advance Order Interval Access Order. If the Company agrees to provide service on an expedited basis, an Expedited Order Charge will apply.

If the Company receives a request for an expedited service date at the time an Access Order is placed, the Expedited Order Charge is calculated by summing all the nonrecurring charges associated with the order and then dividing this total by the number of days in the negotiated service period. The charge is then applied on a per day of improvement basis, per order, but in no event shall the charge exceed fifty percent of the total nonrecurring charges associated with the Access Order.

Issued: February 10, 2006

Effective: February 17, 2006

2. GENERAL REGULATIONS

2.8. ACCESS SERVICE ORDER

2.8.3. ACCESS ORDER MODIFICATIONS (CONT'D)

E. Order Charges

	NONRECURRING CHARGE
1. Partial Cancellation Charge, Per order, per occurrence	ICB
2. Design Change Charge, Per order, per occurrence	ICB
3. Service Date Change Charge, Per order, per occurrence	ICB

Issued: February 10, 2006

Effective: February 17, 2006

2. GENERAL REGULATIONS

2.8. ACCESS SERVICE ORDER (CONT'D)

2.8.4. CANCELLATION OF AN ACCESS ORDER

A. A customer may cancel an Access Order for the installation of service at any time prior to notification by the Company that service is available for the customer's use or prior to the service date, whichever is later. The cancellation date is the date the Company receives written or verbal notice from the customer that the order is to be canceled. The verbal notice must be followed by written confirmation within 10 days. If a customer or end user is unable to accept Access Service within 30 calendar days after the original service date, the customer has the choice of the following options:

1. The Access Order shall be canceled and charges set forth in B., following will apply, or
2. Billing for the service will commence.

If no cancellation request is received within the specified 30 calendar days, billing for the service will commence. In any event, the cancellation date or the date billing is to commence, as applicable, shall be the 31st day beyond the original service date of the Access Order.

B. When a customer cancels a Negotiated Interval Access Order for the installation of service, a Cancellation Charge will apply as follows:

1. When the customer cancels an Access Order, a charge equal to the estimated provisioning costs incurred at a particular date for the service ordered by the Company shall apply.
2. If the Company misses a service date for a Negotiated Interval Access Order by more than 30 days, due to circumstances such as acts of God, governmental requirements, work stoppages and civil commotions, the customer may cancel the Access Order without incurring cancellation charges.

Issued: February 10, 2006

Effective: February 17, 2006

2. GENERAL REGULATIONS

2.8. ACCESS SERVICE ORDER (CONT'D)

2.8.5. MINIMUM PERIOD

- A. The minimum period for which Switched Access Service is provided and for which charges are applicable, is three months.
- B. The following changes will be treated as a discontinuance of the existing service and an installation of a new service. A new minimum period will be established. All associated nonrecurring charges will apply for the new service.
 - A move to a different building.
 - A change in type of service.
 - A change in Switched Access Service Interface Group.
 - Change in Switched Access Service traffic type.

2.8.6. MINIMUM PERIOD CHARGE

When Access Service is disconnected prior to the expiration of the minimum period, charges are applicable for the balance of the minimum period.

The Minimum Period Charge for monthly billed services will be determined as follows:

- A. All unpaid Nonrecurring Charges reasonably expended by Company to establish service to customer, plus;
- B. Any disconnection, early cancellation or termination charges reasonably incurred and paid to third parties by Company on behalf of customer, plus;
- C. All Recurring Charges specified in the applicable Service Order for the balance of the then current minimum period;
- D. Minus a reasonable allowance for costs avoided by the Company as a direct result of customer's cancellation.

In addition to the Minimum Period Charge, Termination Liabilities may apply, as set forth elsewhere, for those services ordered under Term Agreements.

Issued: September 2, 2009

Effective: February 17, 2006

2. GENERAL REGULATIONS

2.9. BILLING AND PAYMENT

The Company shall bill on a current basis all charges incurred by and credits due to the customer. The customer shall receive its bill in a paper format. Such bills are due upon receipt. The Company will, upon request and if available, furnish such detailed information as may reasonably be required for verification of the customer's bill.

All bills for service provided to the customer by the Company are due on the payment due date shown on the bill and are payable in immediately available funds. If such payment due date would cause payment to be due on a Saturday, Sunday or Legal Holiday, payment for such bills shall be due from the customer as follows:

If such payment due date falls on a Sunday or on a Legal Holiday, the payment due date shall be the first non-Holiday date following such Sunday or Legal Holiday. If such payment due date falls on a Saturday or on a Legal Holiday that is observed on Tuesday, Wednesday, Thursday or Friday, the payment due date shall be the last non-Holiday day preceding such Saturday or Legal Holiday.

The customer will be assessed a charge of twenty-five dollars (\$25.00) for each check submitted by the customer to the Company which a financial institution refuses to honor.

If any portion of the payment is received by the Company after the due date, or if any portion of the payment is received by the Company in funds that are not immediately available upon presentment, then a late payment penalty shall be due to the Company. The late payment penalty shall be the portion of the payment not received by the due date, multiplied by a late factor. The late factor shall be 1.5% per month.

2.9.1. TAXES

The customer is responsible for payment of any state sales tax, federal excise tax and any federally mandated surcharges, such as: Federal Universal Service Fund Surcharge, FCC Subscriber Line Charge and Local Number Portability Surcharge. All taxes and fees shall be listed as separate line items on the customer's bill.

Issued: September 2, 2009

Effective: February 17, 2006

2. GENERAL REGULATIONS

2.9. BILLING AND PAYMENT (CONT'D)

2.9.2. CLAIMS AND DISPUTES

In the event that a billing dispute occurs concerning any charge billed to the customer by the Company, the customer must submit a documented claim for the disputed amount. The customer will submit all documentation as may reasonably be required to support the claim. All claims should be submitted to the Company within 120 days of receipt of billing for that service. All disputes between the Company and the customer that cannot be settled through negotiation may be resolved by arbitration upon written demand of either party. Arbitration shall be referred to the American Arbitration Association (AAA) and conducted pursuant to its Commercial Arbitration Rules. The arbitrator shall have the authority to award compensatory damages solely; such award shall be final and binding and may be entered in any court having jurisdiction thereof. The provisions of the Federal Arbitration Act shall govern such arbitration.

This dispute process does not preclude the customer from filing a complaint with the B.P.U..

Customer inquiries or complaints regarding service or accounting may be made in writing or by telephone to the Company at:

Comcast Business Communications, LLC
MCA3 Group
183 Inverness Drive West, 1st Floor
Englewood, CO 80112
888-824-4141

or complaints may be filed with:

New Jersey Board of Public Utilities
Customer Relations
2 Gateway Center
Newark, NJ 07012
201-648-2350
800-624-0241

Issued: February 10, 2006

Effective: February 17, 2006

2. GENERAL REGULATIONS

2.9. BILLING AND PAYMENT (CONT'D)

2.9.3. PAYMENT OF DEPOSITS

To safeguard its interests, the Company may require a customer to make a deposit to be held as a guarantee for the payment of charges. A deposit does not relieve the customer of the responsibility for the prompt payment of bills on presentation. The deposit will not exceed an amount equal to:

- two month's charges for a service or facility which has a minimum payment period of one month; or
- the charges that would apply for the minimum payment period for a service or facility which has a minimum payment period of more than one month; except that the deposit may include an additional amount in the event that a termination charge is applicable.

A deposit may be required in addition to an Advance Payment.

When a service or facility is discontinued, the amount of a deposit, if any, will be applied to the customer's account and any credit balance remaining will be refunded. Before the service or facility is discontinued, the company may, at its option, return the deposit or credit it to the customer's account. If the amount of the deposit is insufficient to cover the balance due to the customer's account, the Company retains the right to collect any amounts owing after the deposit has been applied plus any costs related to the collection of any remaining balance.

Deposits held will accrue interest at a simple interest rate equal to the rate applicable for the late payment charge set forth in 2.9, preceding. Interest will not accrue on any deposit after the date on which reasonable effort has been made to return it to the customer.

2.9.4. ADVANCE PAYMENTS

To safeguard its interests, the Company may require a customer to make an advance payment before services and facilities are furnished. The advance payment will not exceed an amount equal to the non-recurring charge(s) and one month's charges for the service or facility. In addition, where special construction is involved, the advance payment may also include an amount equal to the estimated non-recurring charges for the special construction and recurring charges (if any) for a period to be set between the Company and the customer. The advance payment will be credited to the customer's initial bill. An advance payment may be required in addition to a deposit.

Issued: February 10, 2006

Effective: February 17, 2006

2. GENERAL REGULATIONS

2.10. SPECIAL CONSTRUCTION

All rates and charges quoted herein provide for the furnishing of facilities when suitable facilities are available or where the design or construction of the necessary facilities does not involve unusual costs.

When, at the request of the customer, the Company designs and/or constructs facilities that it would otherwise not construct, or the construction of such facilities involves a greater expense than would otherwise be incurred, Special Construction nonrecurring charges may apply.

2.11. NON-ROUTINE INSTALLATION

At the customer's request, installation and/or maintenance may be performed outside the Company's regular business hours or in hazardous locations. In such cases, charges based on cost of the actual labor, material, or other costs incurred by or charged to the Company will apply. If installation is started during regular business hours but at the customer's request extends beyond regular business hours into time periods including, but not limited to, weekends, holidays, and/or night hours, additional charges may apply.

Issued: February 10, 2006

Effective: February 17, 2006

3. SWITCHED ACCESS SERVICE

3.1. GENERAL

Switched Access Service, which is available to customers for their use in furnishing their services to end users, provides a two-point communications path between a customer's premises and an end user's premises. It provides for the use of common terminating, switching and trunking facilities. Switched Access Service provides for the ability to originate calls from an end user's premises to a customer's premises, and to terminate calls from a customer's premises to an end user's premises in the LATA where it is provided. Switched Access Service must be ordered separately for each LATA in which the customer desires to originate or terminate calls.

3.2. PROVISION AND DESCRIPTION

Switched Access Service is provided in two service categories of standard and optional features called Feature Groups. The Company provides Feature Group B and Feature Group D originating and terminating Switched Access. The service categories are differentiated by their technical characteristics and the manner in which an end user accesses them when originating calls.

3.2.1. FEATURE GROUP B

FGB Access, which is available to all customers, provides trunk side access to Company End Office switches with an associated uniform 950-XXXX access code for the customer's use in originating and terminating communications.

3.2.2. FEATURE GROUP D

FGD Access, which is available to all customers, provides trunk side access to Company End Office switches with an associated uniform 10XX-XXX access code for the customer's use in originating and terminating communications. No access code is required for calls to a customer over FGD if the end user's telephone exchange service is arranged for presubscription to that customer.

3.2.3. 8XX TOLL-FREE ACCESS SERVICE

8XX Toll-Free Access Service is a service offering utilizing originating trunk side Switched Access Service. The service provides for the forwarding of end user dialed 8XX calls to a Company Service Switching Point which will initiate a query to the database to perform the customer identification and delivery function. The call is forwarded to the appropriate customer based on the dialed 8XX number.

Issued: February 10, 2006

Effective: February 17, 2006

3. SWITCHED ACCESS SERVICE

3.3. SWITCHED ACCESS RATE CATEGORIES

The rate categories that apply to Switched Access Service are as follows:

- Carrier Common Line
- Transport (includes Common Transport, Direct Trunk Transport and Local Channel/Entrance Facilities)
- Local Switching
- 8XX Toll-Free Access Service

The following diagram depicts a generic view of the components of Switched Access Service and the manner in which the components are combined to provide a complete access service.

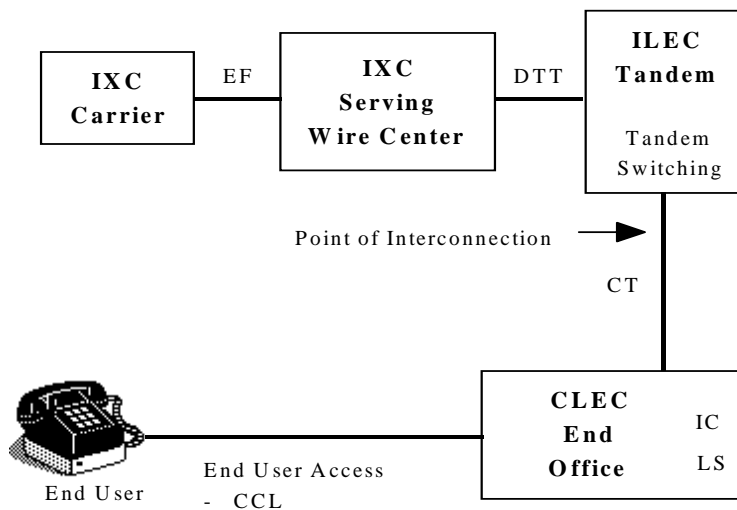

ILEC bills:

EF - Entrance Facility
DTT - Direct Trunk Transport
Tandem Switching

Company bills:

CT - Common Transport
IC - Interconnection Charge
LS - End Office/Local Switching
CCL - Carrier Common Line

Switched Access rates are as set forth in Section 3.4, following.

Issued: February 10, 2006

Effective: February 17, 2006

3. SWITCHED ACCESS SERVICE

3.3. SWITCHED ACCESS RATE CATEGORIES (CONT'D)

3.3.1. CARRIER COMMON LINE

The Carrier Common Line rate category provides for the use of Company common lines by customers for access to end users to furnish customer intrastate communications.

A. Limitations

1. A telephone number is not provided with Carrier Common Line.
2. Detail billing is not provided for Carrier Common Line.
3. Directory listings are not included in the rates and charges for Carrier Common Line.
4. Intercept arrangements are not included in the rates and charges for Carrier Common Line.
5. All trunk side connections provided in the same combined access group will be limited to the same features and operating characteristics.

B. Rate Regulations

Where the customer is provided with Switched Access Service under this Tariff, the Company will provide the use of Company common lines by a customer for access to end users.

1. The Carrier Common Line charges will be billed per access minute to each Switched Access Service customer.
2. When the customer reports interstate and intrastate use of Switched Access Service, the Carrier Common Line charges will be billed only to intrastate.
3. All Switched Access Service provided to the customer will be subject to Carrier Common Line charges.

Issued: February 10, 2006

Effective: February 17, 2006

3. SWITCHED ACCESS SERVICE

3.3. SWITCHED ACCESS RATE CATEGORIES (CONT'D)

3.3.2. TRANSPORT

The Transport rate category provides for transmission facilities between the customer's premises and the End Office or Access Tandem switch(es) where the customer's traffic is switched to originate or terminate its communications.

Switched Transport is a two-way voice-frequency transmission path which may consist of an Entrance Facility (EF), Direct Trunk Transport (DTT) Facility or Common Transport.

A. Common Switched Transport

The Common Switched Transport rate category provides for a portion of the circuit termination equipment at the end points and for a portion of the circuit transmission equipment and facilities between end points.

If the Customer purchases Direct Trunked Transport to the access tandem, the Common Switched Transport rate also applies.

Issued: February 10, 2006

Effective: February 17, 2006

3. SWITCHED ACCESS SERVICE

3.3. SWITCHED ACCESS RATE CATEGORIES

3.3.2. TRANSPORT (CONT'D)

B. Direct Trunk Transport

1. Voice Grade/DSO Facility

A Voice Grade facility is an electrical communications path which provides voice-frequency transmission in the nominal frequency range of 300 to 3000 HZ and may be terminated two-wire or four-wire.

2. DS1 Facility

A DS1 facility is capable of transmitting electrical signals at a nominal 1.544 Mbps, with the capability to channelize up to 24 voice-frequency transmission paths.

3. DS3 Facility

A DS3 facility is capable of transmitting electrical signals at a nominal 44.736 Mbps, with the capability to channelize up to 672 voice-frequency transmission paths.

C. Local Channel/Entrance Facility

The Local Channel/Entrance Facility provides a communications path between the customer's premises and the serving wire center of that premises. The Local Channel/Entrance Facility rate is assessed a monthly fixed charge based on the capacity (e.g., Voice Grade/DS0, DS1, or DS3) ordered.

Issued: February 10, 2006

Effective: February 17, 2006

3. SWITCHED ACCESS SERVICE

3.3. SWITCHED ACCESS RATE CATEGORIES (CONT'D)

3.3.3. LOCAL SWITCHING

The Local Switching rate category provides the local end office switching and end user termination functions necessary to complete the transmission of Switched Access communications to and from the end users served by the Company's End Office.

A. Local Switching Rate Element

The Local Switching rate element provides local dial switching for Feature Groups B and D.

B. Common Trunk Port

The end office Common Trunk Port rate provides for the termination of common transport trunks in shared end office ports. The end office Common Trunk Port rate is assessed on a per-MOU basis to all trunkside originating and terminating access minutes utilizing tandem routing to an end office.

C. Dedicated Trunk Port

The end office Dedicated Trunk Port rate provides for the termination of a trunk to a dedicated trunk port in an end office. The rate is assessed per month for each FG trunk in service directly routed (via DTT) between the SWC and the end office.

D. Interconnection Charge

The Interconnection Charge shall be assessed upon all customers interconnecting with the Company's switched access network. Interconnection is applicable to all switched access originating and terminating minutes of use.

Issued: February 10, 2006

Effective: February 17, 2006

3. SWITCHED ACCESS SERVICE

3.3. SWITCHED ACCESS RATE CATEGORIES (CONT'D)

3.3.4. 8XX TOLL-FREE ACCESS SERVICE

8XX Toll-Free Access Service is a service offering originating trunk side Switched Access Service. The service provides for the forwarding of end user dialed 8XX calls to a Company Service Switching Point which will initiate a query to the database to perform the customer identification and delivery functions. The call is forwarded to the appropriate customer based on the dialed 8XX number. In addition, the customer has the option of selecting the 8XX Optional Features Package.

1. Customer Identification Charge

The 8XX Toll-Free Access Service Customer Identification Charge applies for the identification and delivery of the appropriate customer. The charge is assessed to the customer on a per query basis and may include an area of service which may range from a single NPA-NXX to an area consisting of all NPAs in the State of New Jersey.

2. POTS Translation Charge

The POTS Translation Charges provides the option of having the ten digit POTS number NPA + NXX-XXXX delivered instead of the 8XX dialed number 8XX + NXX-XXXX delivered to the service provider.

A POTS Translation Charge is assessed per call in addition to the 8XX Customer Identification Charge.

3. Call Handling and Destination Feature Charge

The 8XX Optional Features Package, available only with 8XX Toll-Free Access Service, provides feature functionality in addition to the basic query. The feature package may include various destination options such as carrier selection, time of day routing, day of week routing, specific date routing, geographic routing, routing based on percent of allocation, and emergency routing profiles.

A Call Handling and Destination Feature Charge is assessed on a per-query basis, in addition to the Customer Identification Charge and the POTS Translation Charge.

Issued: February 10, 2006

Effective: February 17, 2006

3. SWITCHED ACCESS SERVICE

3.4. SWITCHED ACCESS RATES AND CHARGES

3.4.1. SERVICE IMPLEMENTATION

	NONRECURRING CHARGE
A. Installation Charge, Per Location, Per Order	
1. First Trunk	\$0.00
2. Each Subsequent Trunk	0.00

3.4.2. CARRIER COMMON LINE

	RECURRING RATE PER MOU
A. Originating	\$0.011716
B. Terminating	0.011716

3.4.3. TRANSPORT

A. Common Switched Transport	0.0004500
------------------------------	-----------

Issued: February 10, 2006

Effective: February 17, 2006

3. SWITCHED ACCESS SERVICE

3.4. SWITCHED ACCESS RATES AND CHARGES

3.4.3. SWITCHED TRANSPORT (CONT'D)

B. Local Channel/Entrance Facility

	NONRECURRING CHARGE		MONTHLY RATE
	FIRST	ADD'L	
1. VG/DS0	\$0.00	\$0.00	ICB
2. DS1	0.00	0.00	ICB
3. DS3	0.00	0.00	ICB

C. Direct Trunk Transport

	NONRECURRING CHARGE		MONTHLY RATE
	FIRST	ADD'L	
1. VG			
• Per Mile		-	ICB
• Termination		\$ 0.00	ICB
2. DS0			
• Per Mile		-	ICB
• Termination		0.00	ICB
3. DS1			
• Per Mile		-	ICB
• Termination		0.00	ICB
4. DS3			
• Per Mile		-	ICB
• Termination		0.00	ICB

Issued: February 10, 2006

Effective: February 17, 2006

3. SWITCHED ACCESS SERVICE

3.4. SWITCHED ACCESS RATES AND CHARGES (CONT'D)

3.4.4. LOCAL SWITCHING

A. Local Switching	RECURRING RATE PER MOU
1. Originating Access	\$0.0089340
2. Terminating Access	0.0089340
3. Common Trunk Port	0.0000000
4. Interconnection Charge	0.0000000
	MONTHLY RATE
5. Dedicated Trunk Port	
a. DS0/VG, per trunk	ICB
b. DS1, per trunk	ICB

3.4.5. 8XX TOLL-FREE ACCESS

A. 8XX Toll-Free Access Service	RECURRING RATE PER QUERY
1. Customer Identification Charge	\$0.0021540
2. POTS Translation Charge	0.0000000
3. Call Handling and Destination Feature Charge	0.0000000

Issued: February 10, 2006

Effective: February 17, 2006

4. SPECIAL ACCESS SERVICE

4.1. GENERAL

Special Access Services are not generally available but may be provided subject to the terms, conditions, and limitations as set forth in Section 5.3, following, for Special Assemblies and Individual Case Basis Arrangements.

Issued: February 10, 2006

Effective: February 17, 2006

5. MISCELLANEOUS SERVICES

5.1. PRESUBSCRIPTION

The Company will provide 1+presubscription or 10XXX equal access consistent with the equal access rules of the B.P.U. and of the Federal Communications Commission to enable end users to access an interexchange carrier (IC) for intrastate toll calling.

Presubscription is an arrangement whereby an end user may select and designate to the Company an Interexchange Carrier (IC) to access, without an access code, for interexchange calls. This IC is referred to as the end user's Primary Interexchange Carrier (PIC). The end user may select as its PIC any IC that orders originating FGD Switched Access Service at the end office that serves the end user. After the end user's initial selection of a predesignated IC, for any additional change in selection, a nonrecurring charge as set forth in 5.4, following, applies.

New end users who are served by end offices equipped with FGD, will be asked to presubscribe to an IC at the time they place an order with the Company for Exchange Access Service. They may select either of the following options. There will be no additional charge for this initial selection:

- Designate an IC as a PIC and dial 10XXX to reach other ICs.
- Designate that they do not want to be presubscribed to any IC and choose to dial 10XXX for all calls to all ICs.

Subsequent to the installation of Exchange Access Service, and after the end user's initial selection of a PIC, for any additional change in selection, a nonrecurring charge as set forth in 5.4, following, applies.

Issued: September 1, 2009

Effective: February 17, 2006

5. MISCELLANEOUS SERVICES

5.2. UNAUTHORIZED PRIMARY INTEREXCHANGE CARRIER CHANGE

An unauthorized Primary Interexchange Carrier (PIC) change is a PIC change that is requested by an interexchange carrier (IC) when the Local Exchange Service customer, or their authorized agent, denies authorizing the PIC change and the IC is unable to produce a valid letter of authorization for the change from the customer or the customer's authorized agent.

The interval during which a customer may submit a claim for an unauthorized PIC change will be twelve months from the date of the original PIC change.

An unauthorized PIC change is subject to the charge specified in 5.4, following.

5.3. SPECIAL ASSEMBLIES AND INDIVIDUAL CASE BASIS ARRANGEMENTS

Arrangements will be developed on an Individual Case Basis (ICB) in response to a bona fide request from a customer or prospective customer to develop a bid for any switched or special access service that the Company is technically capable of providing but which is not offered under this Tariff (special assembly), or to develop a competitive bid for a service that the Company offers under this Tariff (ICB). Rates quoted in response to such competitive requests may be different than those specified for such services in this Tariff. ICB and special assembly rates will be offered to the customer in writing and on a nondiscriminatory basis. Customers served on a nontariffed basis for services offered under this Tariff as of the effective date hereof shall be entitled to continue their existing serving arrangements under the same terms and conditions as "special assemblies," but those terms and conditions will not necessarily be available to new customers when the same service is available under this Tariff. In addition, the Company may from time to time offer promotional or other special discounts to customers who initiate service within the time contemplated by the promotional or other special discount offer.

ICB arrangements will be made where Customer-specific requirements involve special facilities, equipment, construction, design and engineering, and/or power or other utility requirements, unusual site conditions, deviations from the Technical Specifications, unique Services or components of Service not specified in this Tariff, and other unique or special circumstances, all as determined solely by the Company. Rates and charges for ICBs will reflect the costs incurred by the Company and may include, but are not limited to, monthly rates, nonrecurring charges, or combinations thereof.

Issued: February 10, 2006

Effective: February 17, 2006

5. MISCELLANEOUS SERVICES

5.4. RATES AND CHARGES

	NONRECURRING CHARGE
A. Presubscription Charge	
- Per Telephone Exchange Service Line or Trunk	5.00
B. Unauthorized PIC Change Charge	
- Per occurrence	21.50